

FV100-2S Series

FEATURES

- **Control Mode:** V/F control; Open-loop vector control
- **Carrier frequency** up to 15KHz
- **Auto torque boost and auto slip compensation function**
- **Built-in PID control**
- **Standard equipped Modbus (RS485 baud rate up to 38400bps)**
- **Sleep/wake up function**



DESCRIPTION

The FV100-2S Series is a rugged line of AC Variable Frequency Drives for OEM and Industrial applications, combining high performance and cost efficiency into one powerful package. Available in input voltages of 240VAC and capable of powering AC motors from 0.50 to 5Hp, these VFDs are great for normal duty and soft-start operation. These drives provide energy savings and increased efficiency, making them ideal for fan, pump, and HVAC applications. They are equipped with a number of different features such as momentary power loss restarts, auto-acceleration/deceleration, and sensorless vector control. These features make the VFDs compatible with most AC motors and allow for flexibility within an application.

DIMENSIONS

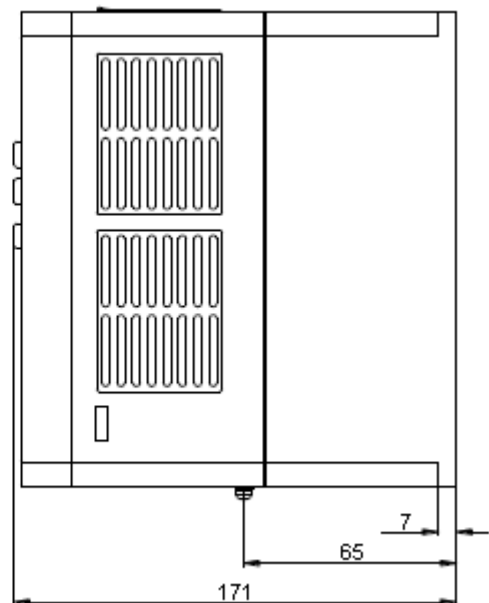
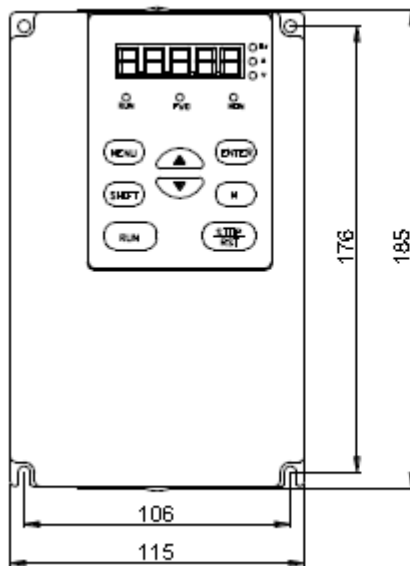

L011446

FV100-2S Series



SPECIFICATIONS

Item #	Input Voltage Range	Max Power (KW)	Max Power (HP)	Rated Current (A)	Overload Tolerance for One Minute (A)	Installation Type
FV100-2S-0004G	Single-Phase, 240V	0.4	0.5	2.5	2	Cabinet or Enclosure
FV100-2S-0007G	Single-Phase, 240V	0.75	1	4.0	3	Cabinet or Enclosure
FV100-2S-0015G	Single-Phase, 240V	1.5	2	7.5	6	Cabinet or Enclosure
FV100-2S-0022G	Single-Phase, 240V	2.2	3	10	11	Cabinet or Enclosure
FV100-2S-0037G	Single-Phase, 240V	3.7	5	16	15	Cabinet or Enclosure

Specification	FV100-2S				
	0004	0007	0015	0022	0037
The Power of Suitable Motor (KW)	0.4	0.75	1.5	2.2	3.7
Output Voltage (VAC)	Three Phase, 0~Input Voltage				
Rated Output Current (A)	2.5	4.0	7.5	10	16
Overload Capacity	150% 1 Minute; 180% 10 Seconds; 200% 0.5 Second; 10 Minutes Interval (Inverse Time Limit Speciality)				
Rated Input Voltage/Frequency	Single Phase, 240VAC; 50Hz/60Hz				
Allowable Input Voltage Range	180V-260VAC; Voltage Unbalancedness:≤3%; Allowable Frequency Fluctuation; ± 5%				
Rated Input Current (A)	5.3	8.2	14.0	23.0	32.0
Brake Unit	Built-In				
Protection Class	IP20				
Cooling Method	Air Cooling	Cooling by Fan			

WIRING DIAGRAM

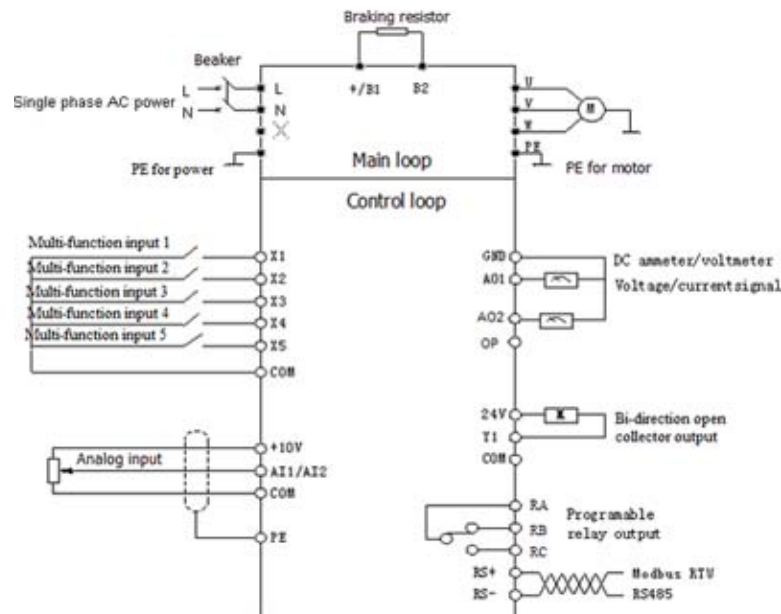

L011446

INPUT	
Rated Voltage/Frequency	Single Phase, 240VAC; 50Hz/60Hz
Allowable Voltage Range	180VAC~260VAC; Voltage Unbalanceness:<3%; Frequency: ±5%
OUTPUT	
Voltage	0~Rated Input Voltage
Frequency	0Hz-300Hz (0Hz-1000Hz Custom)
Overload Capacity	G Type: 150% Rated Current for 1 Minute, 180% Rated Current for 10 Seconds
MAIN CONTROL CHARACTERISTICS	
Control Method	Vector Control Without PG, V/F Control
Starting Torque	0.5Hz: 150% Rated Torque (Vector Control Without PG)
Frequency Accuracy	Digital Setting: Max. Frequency x ±0.01%; Analog Setting: Max. Frequency x ±0.2%
Frequency Resolution	Digital Setting: 0.01Hz; Analog Setting: Max. Frequency x 0.05%
Torque Boost	Manual Torque Boost: 0%-30.0%
V/F Pattern	4 Patterns: 1 V/F Curve Mode Set by User and 3 Kinds of Torque-Derating Modes (2.0 Power, 1.7 Power, 1.2 Power)
Acceleration/Deceleration Curve	Linear Acceleration/Deceleration. Four Kinds of Acceleration/Deceleration Time
Auto Current Limit	Limit Current During Operation Automatically to Prevent Frequent Overcurrent Trip
CUSTOMIZED FUNCTION	
Operation Command	Keypad Setting, Terminal Setting, Communication Setting
Frequency Command	Digital Setting, Analog Voltage Setting, Analog Current Setting, Pulse Setting
Auxiliary Frequency Setting	Implement Flexible Auxiliary Frequency Trim and Frequency Synthesis
Analog Output	1 Channel Analog Output (0/4~20mA or 0/2~10V)
Protection Function	Overcurrent Protection, Overvoltage Protection, Undervoltage Protection, Overheat Protection, Overload Protection, Missing Phase Protection (Selectable)
ENVIRONMENT	
Altitude	Derated Above 1000m, The Rated Output Current Shall be Decreased by 10% for Every Rise of 1000m
Ambient Temperature	-10°C~ + 40°C (Derated at 40°C~50°C)
Humidity	5%~95%RH, Non-Condensing
Vibration	Less Than 5.9m/s ² (0.6g)
Storage Temperature	-40°C~ + 70°C